



THERMAL MONOCULAR STRIDE

ST6

User Manual v1.0



5 YEAR
WARRANTY
Thermal Devices

3 YEAR
WARRANTY
Digital Devices

**CUSTOMER
SERVICE**

+1 (800) 580-5281
info@rix-nv.com



We appreciate you choosing RIX.
Please read the instruction manual carefully before using this product.
Thank you and happy hunting!



RIX



STRIDE ST6
RX

▼ TABLE OF CONTENTS

01. Product Overview	...01						
02. Product Features	...01	06. Device Modes	...06	10. Standby Mode	...11	14. Firmware Update	...21
03. Product Parameters	...02	07. Power Supply	...08	11. Status Icon	...12	15. App Description	...23
04. In the Box	...04	08. Buttons Operation	...09	12. Shortcut Functions	...13	16. Product Maintenance	...24
05. Product Appearance	...05	09. Power On/Off	...10	13. Product Menu	...17	17. Product Troubleshooting	...24

01 PRODUCT OVERVIEW

The STRIDE ST6 utilizes advanced thermal imaging technology and a high sensitivity infrared detector for superior outdoor night vision. It can be used handheld or mounted on a helmet. The STRIDE ST6 is lightweight, compact, and has a long runtime, making it ideal for night hunting and observation. In addition, it has a wide range of functions such as photography and video recording.

02 PRODUCT FEATURES

It can be used handheld or mounted on a helmet	Sensor Resolution:640x512
Detection distance: about 1800m/1969yd	64G memory, built-in
It can take photos and videos	Image transfer via Wi-Fi and mobile apps
18650 replaceable battery	Operating time: up to 10h

03 PRODUCT PARAMETERS

STRIDE ST6		
Sensor	Type	VOx Uncooled
	Resolution, pixels	640x512
	Pixel pitch, μm	12
	NETD, mK	<25
	Frame Rate, Hz	50
Optics	Objective Lens, mm	26.7
	Optic Zoom, x	1
	Field of View	16.3° x 12.3°
	Digital Zoom, x	1x,2x,4x,6x
	Eye Relief, mm	20
	Diopter Adjustment, D	-5 to +2
Range Performance	Detection Range, m/yd	1800m/1969yd
Display	Type	OLED
	Resolution, pixels	1024x768

STRIDE ST6		
Video Recorder	Video / Photo Resolution, pixels	640x512
	Video / Photo Format	.mp4 / .jpg
	Built-in Memory, GB	64
Wi-Fi	Wireless Protocol	Wi-Fi
	Frequency, GHz	2.4
Environmental Characteristics	Degree of Protection, IP code	IP67
	Operating Temperature Range, °F	-4 to +122
	Battery Type	18650
	Operating Time on Battery Pack (at t=72°F), h	Up to 10
Weight & Size	External Power Supply	5V (Type-C USB)
	Dimensions, inch	4.5x2.8x1.9
	Weight, lb	<0.6 (without battery)

04 IN THE BOX

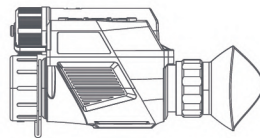

The Stride Series ST6

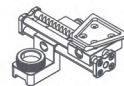

Adapter Kit
(between the device and the helmet mount)



Lens Cloth

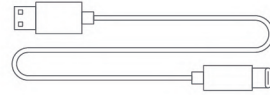

USB Type-C Cable



Carrying Bag and Strap



Lanyard, x1



Screw
(securing the lanyard to the device)

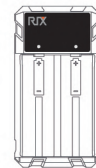

Battery Charger



Battery
(in the device)

Note

The box also includes an instruction manual, a quick to use guide, and a thank you letter.

05 PRODUCT APPEARANCE

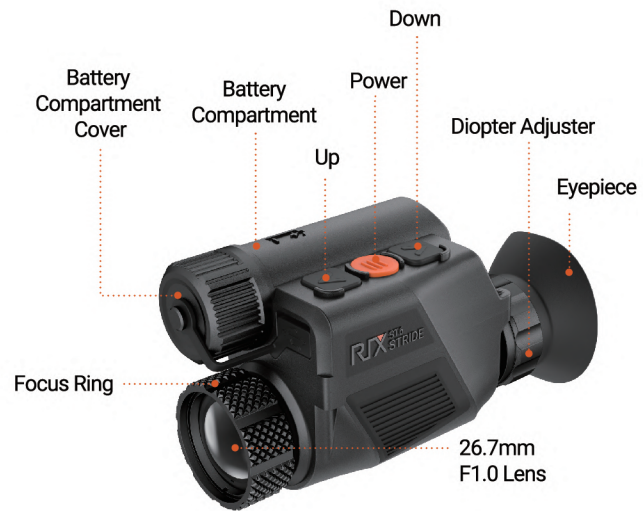

06 DEVICE MODES

Handheld Mode

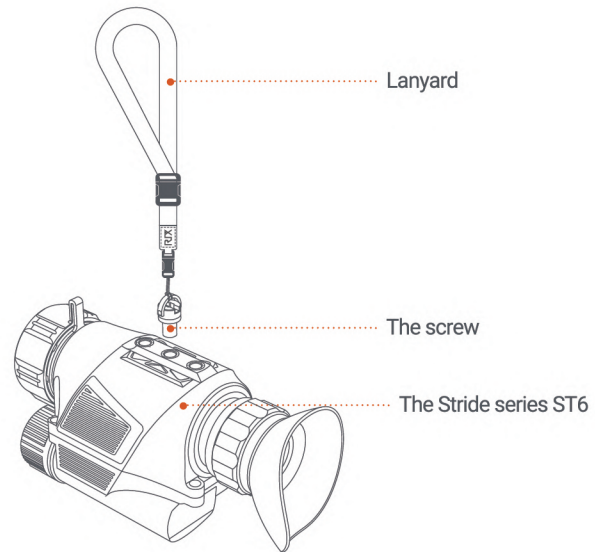

Helmet Mode

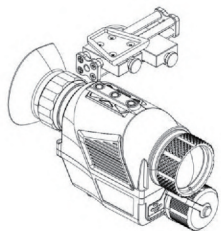

Step 1:

Attach the adapter kit to the device.

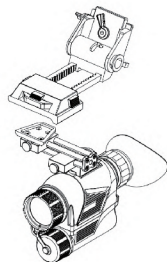

Step 2:

Attach the helmet mount to the adapter kit.

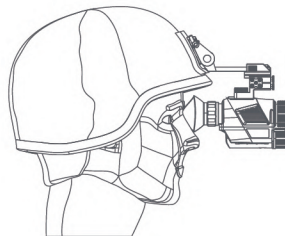

Step 3:

Attach the helmet mount, the adapter kit, and the device to the helmet.

07 POWER SUPPLY

The STRIDE ST6 is powered by a 18650 replaceable battery.

- ▶ Rotate the battery compartment cover until it is unscrewed.
- ▶ Install the battery into the compartment, positive (+) pole inward and negative (-) pole outward, as indicated by the symbols outside the battery compartment.
- ▶ After inserting the battery, tighten the battery compartment cover.

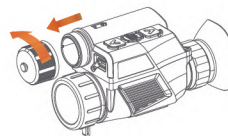

Step 1

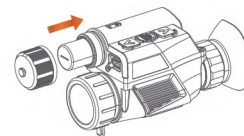

Step 2

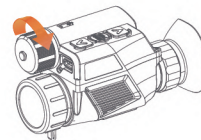

Step 3

WARNING

- ▶ Please remove the battery if the device is not in use for a long time.
- ▶ Do NOT power the device with a modified or damaged battery.
- ▶ Do not use the battery at a temperature above 122°F as it may reduce the service life of the battery.

Note

The decrease in battery pack capacity under sub-zero temperatures is a normal occurrence and not a factory defect.

08 BUTTONS OPERATION

Button	Current Status	Press	Press and Hold
Up	Home screen	Adjust the magnification	Manual Image Correction
	Menu screen	Moves to the previous option/Increases the value	—
Power	Powered off	—	Power on the device
	Home screen	Switch image mode	Power off the device
	Menu screen	Confirm	Exit Menu
Down	Home screen	Start / Stop video recording	Take a photo
	Menu screen	Moves to the next option/Decreases the value	—
Up+Power	Home screen	PIP ON/OFF	—
Down+Power	Menu screen	Enter menu screen	—

09 POWER ON/OFF

Power On / Starting

1. Open the lens cap.
2. Press and hold the Power button for 3 seconds to turn on the device. The RIX logo will appear.

Powering Off / Stopping

On the home screen, press and hold the Power button and the shutdown countdown appears on the screen. Continue to press and hold the Power button for 3 seconds before the device turns off.

Note

Releasing the Power button and then pressing the Up or the Down button at any time during this shutdown cycle will stop the shutdown.

Warning

If using an external power supply, do not disconnect the power supply when saving data, otherwise the data may not be saved.

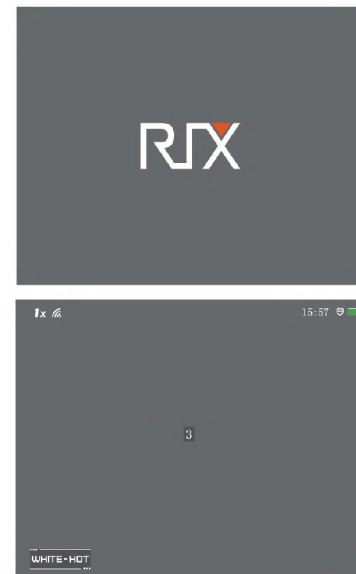

10 STANDBY MODE

When the device is mounted on a helmet, the device enters standby mode if it is flipped upwards and angled above 75 degrees. At this point, the device's screen automatically turns off. When the device is flipped to an angle less than 75 degrees, the device exits standby mode, at which point the screen turns on.

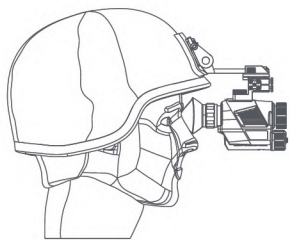

The screen is on.

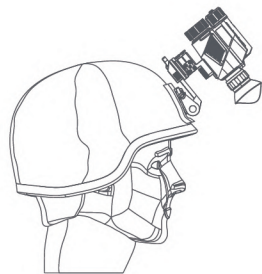

The device flips up more than 75 degrees, screen off.

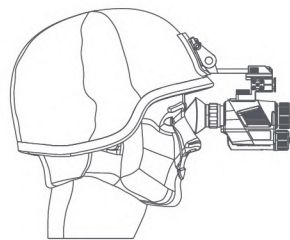

The flipping angle of the device is less than 75 degrees, screen on.

11 STATUS ICON

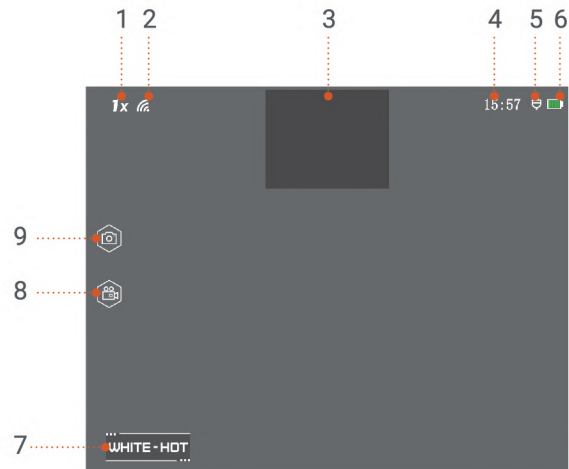

1. Digital zoom: 1x, 2x, 4x, 6x.
2. Wi-Fi icon: Display Wi-Fi on/off status.
3. PIP(Picture in Picture).
4. Clock.
5. USB icon: The device is connected to a power source or computer via a data cable. Otherwise, not displayed.
6. Battery level.
7. Image mode: White Hot, Black Hot, Iron, Green, Edge, Red.
8. Record Video.
9. Take Photo.

12 SHORTCUT FUNCTIONS

The shortcut functions can be directly used through buttons on the home screen.

Digital Zoom (Up Button)

Briefly press the Up button to zoom in and out on the subject. The status icon provides a real-time display of the magnification level as you adjust it.

Manual Image Correction (Up Button)

This function is effective for enhancing degraded or uneven images. By balancing the background temperature of the detector, the function can eliminate image defects and improve overall quality.

If you feel that the image is bad, you can press and hold the Up button until hearing a clicking sound.

Photo/Video (Down Button)

▶ Video Recording

Press the Down button to start recording. Press the video button again to stop and save the video recording.

▶ Photo Taking

Press and hold the Down button to take a photo, and the screen will freeze with a photo icon.

Note

- ▶ The photos and videos taken will be saved on the built-in memory card respectively in the format of YYYYMMDD_hhmmss.jpg (photos) and YYYYMMDD_hhmmss.mp4 (videos). It is recommended to synchronize the device time and date through the app before using the photo/video mode. You can find specific operation instructions in the RIX App which is available to download on our website, www.rix-nv.com.
- ▶ The maximum duration of a video recording file is 20 minutes. When the duration is more than 20 minutes, the video will be automatically recorded onto a new file.
- ▶ For operations of photos and videos, turn on the device and connect it to the computer through a data cable. Turn on the device's Wi-Fi function. Double-click MY COMPUTER on the Desktop Screen, find the device named "Camera", and double-click to access the photos and videos.
- ▶ You can easily optimize the storage space by either deleting or moving the media files to a storage device.
- ▶ To avoid damaged video footage, please turn off the device properly.

PIP(Picture in Picture, Up + Power Button)

On the home screen, press the Up + Power button to enable the PIP function. At this point, a small window will appear at the top of the screen to enlarge the middle area of the screen. This allows users to easily observe target details and aim more accurately.



Image Mode (Power Button)

Press the Power button to switch the image mode including: White Hot, Black Hot, Iron, Green, Edge, and Red.



White Hot (default)



Black Hot

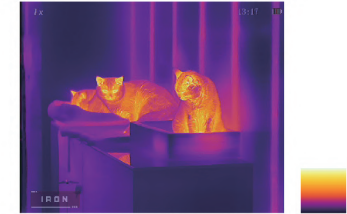

Iron

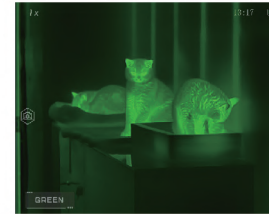

Green



Edge

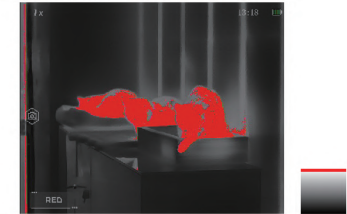

Red

On the home screen, press the Down+Power button to enter the menu screen.



Image

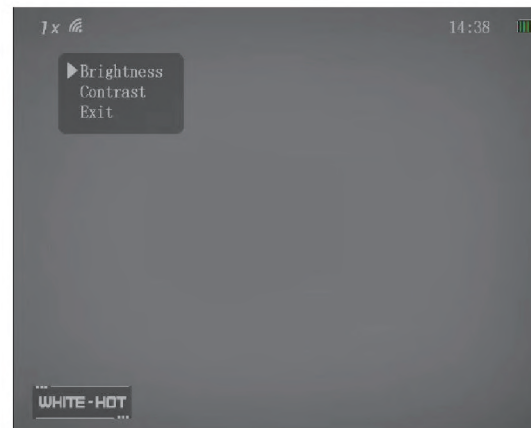

- ▶ Brightness: set the screen brightness to 1-5; the default value is 3.
- ▶ Contrast: set the image contrast to 1-5; the default value is 3.

Settings

- ▶ **Wi-Fi:** It can be enabled or disabled in the settings, with Wi-Fi being disabled by default. When Wi-Fi is enabled, the Wi-Fi icon will be displayed on the home interface. After about 10 seconds, a mobile device can find the access point named XWIFI_XXXXX, and the default password is 12345678. Once successfully connected to Wi-Fi, you can use the app and a data cable to observe or capture images/videos.
- ▶ **Correcting:** Auto image correction, can be enabled or disabled in the settings, with correcting being disabled by default. No matter if the function is on or off, the manual image correction function can be used on the home screen.

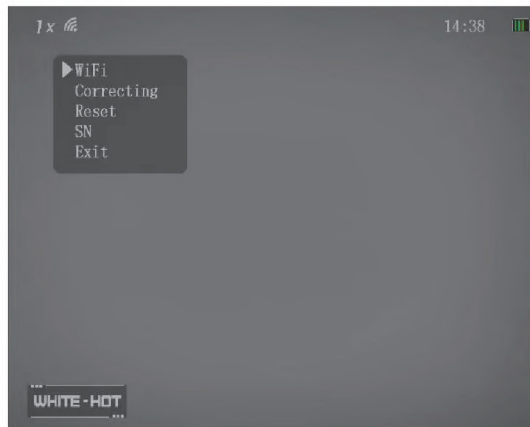

- ▶ **Reset:** Allows you to restore the device to its factory settings. Selecting this option and clicking OK will reset the device data to its default settings and exit all menus.
- ▶ **SN:** Displays product serial number and product software version information.

Note

- ▶ You could change the name and password of the Wi-Fi in the app.
- ▶ In the app, find the My Device icon, and click it to enter the interface for settings.
- ▶ In the text box, enter and submit the new Wi-Fi name (SSID) and password.
- ▶ After submitting the changes, restart the device to activate them.

If the device is reset, the name and password of the Wi-Fi will also be restored to the default settings.

14 FIRMWARE UPDATE

By using the function, the device can run more stable and function rich system firmware.

Step 1: The device is connected to the mobile via Wi-Fi.

Step 2: Open the RIX+ app and connect to the device, then click on “Me”.

Step 3: Click on “Stride-ST6”.

Step 4: If there is a new system firmware, the APP will prompt whether to update it. If the update is confirmed, the app downloads the new system firmware and transfers it to the device.

Step 5: After the new system firmware is transmitted to the device, a system firmware update prompt will pop up on the device screen. Select OK and wait for the device to complete the update.

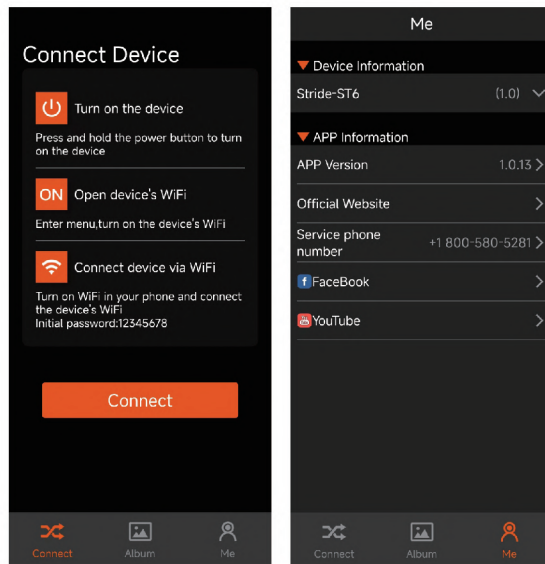

Step 6: After the system firmware update is completed, the device needs to be restarted, which can be done through the Power button or by removing the battery. After restarting, if the device is functioning properly, the entire update process has been completed.

Note

- ▶ During the system firmware update process, if the battery level is too low, the update cannot proceed. So, please use a fully charged battery.
- ▶ Regardless of whether a new system firmware is available or not, if you connect your device for the first time through the app, there will be no indication that a new system firmware is available.

Warning:

If the device loses power during the firmware update process, it can cause damage to the device.

15 APP DESCRIPTION

The device comes with a dedicated app. By connecting the device to the app on a cell phone, tablet, or laptop you can enjoy real-time image transmission, perform device operations, and receive program updates. Download instructions for using the app from the official website, www.rix-nv.com.

Users have the option to update the firmware of the device by utilizing the app or downloading the latest version from www.rix-nv.com.

► About App

You can download and install the app on the official website (www.rix-nv.com) or by searching RIX+ in an app store.



Linktree



RIX+ Android



RIX+ IOS

RoHS  CE
FCC ID: 2A7ZZ-45-00

16 PRODUCT MAINTENANCE

Prior to using the device, it is important to conduct a thorough technical inspection to ensure the following items are in proper working condition.

To remove dust and dirt from the metal and plastic parts, use a cotton cloth and gently wipe the surface clean.

Make sure that the 18650 battery being used is free from any bulges or deformations and that the plastic cover is not damaged.

17 PRODUCT TROUBLESHOOTING

Refer to the table below, which outlines potential issues that may arise during operation. For product issues that can not be remedied or are not listed below, please contact RIX Optics customer support by visiting www.rix-nv.com.

Fault	Possible Causes	Solutions
The device cannot be started.	The battery is out of charge.	Charging
The device cannot be powered by an external power supply	The USB cable is damaged.	Replace the USB cable.
	The external power supply is insufficient.	If necessary, check the external power supply.
The image is too dark.	The screen is not bright enough.	Adjust the display brightness
The device cannot connect to a mobile phone or computer.	The Wi-Fi password is incorrect.	Enter the correct password or reset the device back to factory setting.
	There are too many Wi-Fi networks in the range of the device, which may cause interference.	For a stable network connection, it is recommended to relocate the device to an area with a lower number of Wi-Fi networks.
Wi-Fi signals are lost or interrupted.	The device is beyond Wi-Fi coverage. There is blocking (such as concrete walls) between the device and the receiver.	Move the device to a place where you can receive Wi-Fi signals.
When the device is used at a low temperature, the imaging quality is poorer than that at a normal temperature.	At temperatures above 0°C, the temperature rise varies with the observed objects (environment and background) due to different heat conductivity coefficients. As a result, high-temperature contrast occurs, and the image quality is better. At low temperatures, the observed targets (background) usually cool down to a similar temperature because of reduced temperature contrast. Therefore, the image quality (details in particular) is poor, which is a characteristic of thermal imaging devices.	

